

Software

Addressing 5G and MIMO Design with Circuit/Antenna In-Situ Simulations with NI AWR Software

Electromagnetic (EM) simulation software is commonly used to simulate antennas with multiple feeds, including phased arrays, stacked radiators with different polarizations, and single apertures with multiple feed points. These types of antennas are popular for communication systems where multiple-in-multiple-out (MIMO) and polarization diversity antenna configurations are being used. Their use is likely to explode with the rollout of 5G wireless systems over the next several years.

The beam of multiple-feed antennas is controlled by changing the phase and amplitude of the signals going into the various feeds. An accurate simulation of such a system must account for the interaction that occurs between the antenna elements and the driving feed network. The problem for simulation software is that the antenna and the driving feed network influence each other. The antenna's pattern is changed by setting the input power and relative phasing at its various ports. At the same time, the input impedances at the ports change with the antenna pattern. Since input impedance affects the performance of the nonlinear driving circuit, the changing antenna pattern affects the overall system performance.

Until now, engineers have been forced to simulate the coupled circuit/antenna effects manually using an iterative process. For example, first the antenna is driven with idealized sources with known phasing at the input ports. The impedance of

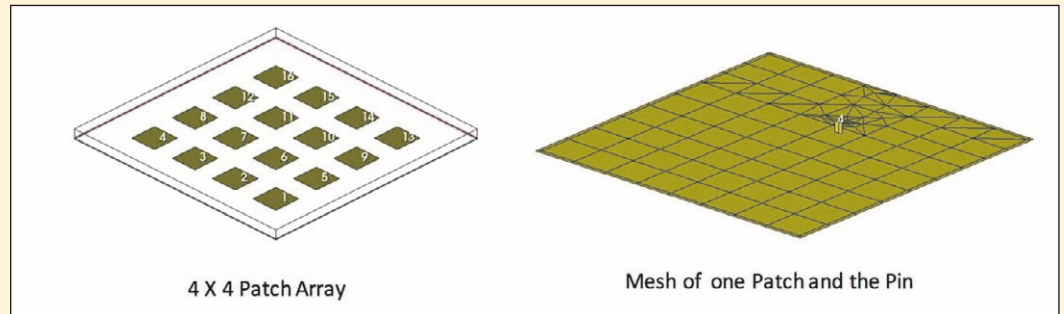

Figure 1: A 4X4 patch array (left), where each patch is fed by a pin coming up from the bottom ground plane. The right picture shows the mesh of one element, and the driving pin to the ground plane

the ports is then used as the load impedance for the driving circuit. The process is then iterated until convergence is reached. This procedure is awkward and time consuming. Fortunately, there is

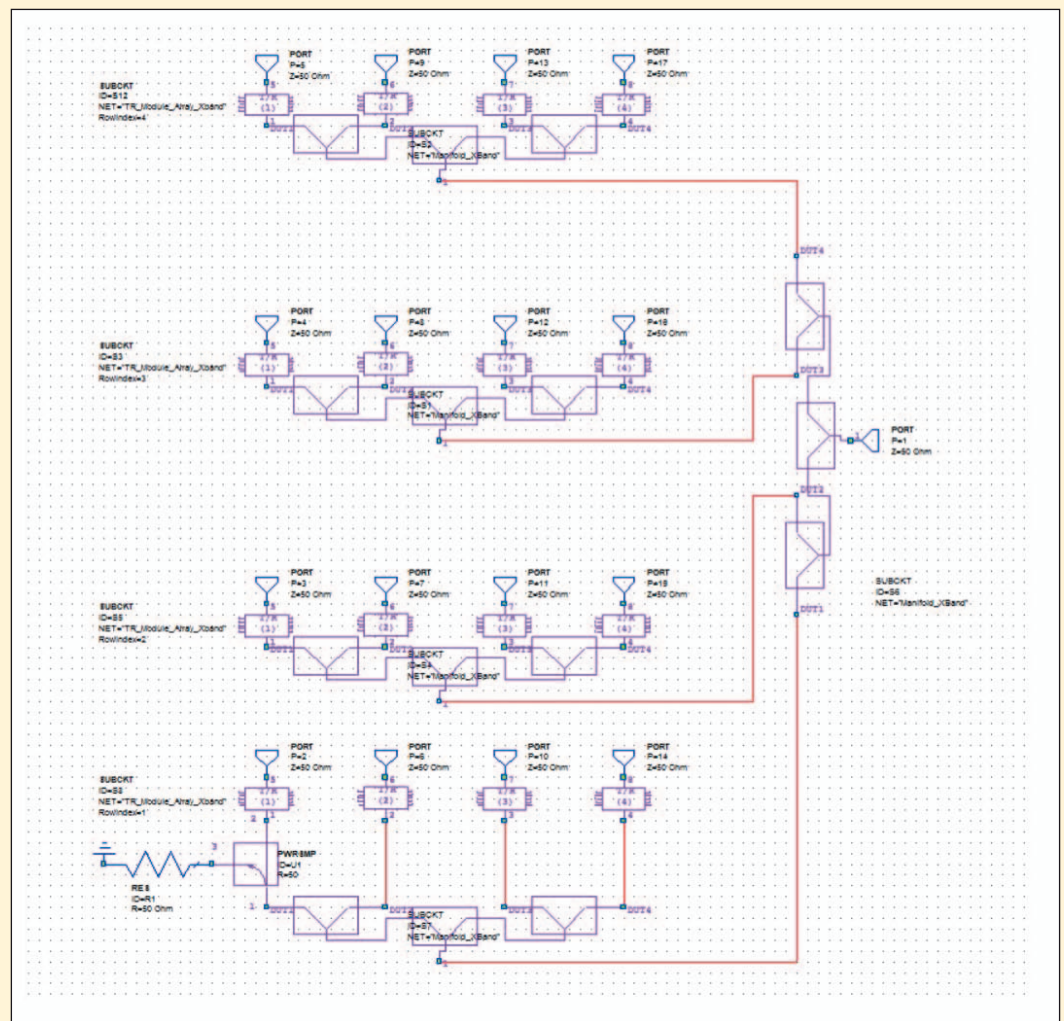

Figure 2: Corporate feed network for the patch array. Each element is driven by a MMIC amplifier, and controlled by a phase shifter and attenuator

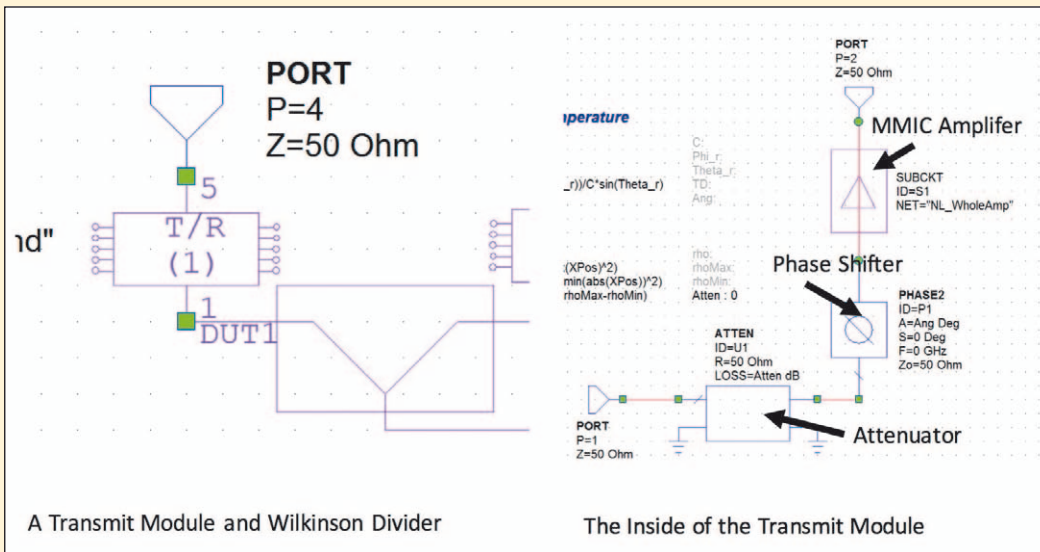

Figure 3: The picture shows one Wilkinson divider and the transmit module, which contains the phase shifter, attenuator, and a MMIC amplifier

a faster, more accurate way to attain the final result. The in-situ measurement feature in NI AWR Design Environment™, specifically Microwave Office circuit design software, enables communication between the circuit and antenna, thus automatically accounting for the coupling between the circuit and the antenna in an easy-to-use framework. The designer identifies the antenna data source, the circuit schematic driving the antenna, and the measurement under consideration; for example, the power radiated over scan angle. This concept is illustrated in this application note using two phased-array examples in which the antennas are simulated in AXIEM 3D planar and Analyst™ 3D finite-element method (FEM) EM simulators respectively.

Patch Microstrip Array Optimized Using Microwave Office

In this example a 4X4 patch array that is driven by a corporate feed network with a phase shifter and attenuator at each element is simulated. A microwave monolithic integrated circuit (MMIC) power amplifier (PA) is placed at each element before its corresponding phase shifter. The array is only simulated once in the EM simulator. The resul-

ting S-parameters are then used by the circuit simulator, which also includes the feed network and amplifiers. As the phase shifters are tuned over their values, the antenna's beam is steered. At the same time, each amplifier sees the changing impedance at the antenna input it is attached to, which affects the amplifier's performance. The PAs are nonlinear, designed to operate at their 1 dB compression point (P1dB) for maximum efficiency. They are therefore sensitive to the changing load impedances presented by the array.

The combined circuit and EM simulations are necessary for a number of reasons. First, the EM simulation is necessary because the antenna elements interact with each other, which can significantly degrade the antenna's performance. An extreme example of this is scan blindness, where the interaction between the elements causes no radiation to occur at certain scan angles. The coupling between the elements can also lead to resonances in the feed network. In order to optimize the feed network to account for deficiencies in the antenna, the entire array combined with the entire circuit must be optimized. It is critical to simulate the feed network itself since resonances

can build up due to the loading at the antenna ports.

Another important point, but often neglected, is that the PA driving the antenna requires a nonlinear circuit simulation. It is therefore important that the antenna's S-parameters include a DC simulation point and values at the various harmonics used in the harmonic balance simulation. Otherwise it is possible to have unpredicted degradations in system performance due to poor matching at the harmonic frequencies or inaccurately specified DC biasing.

Figure 1 shows the 4X4 patch antenna array. Each patch is fed individually by a pin going to the ground below. The port is placed at the bottom of the pin. AXIEM, which is used for the planar EM simulations, has

the ability to ground a port with a metal strap, which is used as the pin. This type of simulator is ideal for planar patch arrays that may require a 3D EM simulator depending on the structure details, since the patch is not in a package and radiation effects are therefore included automatically. It should be noted that the simulation techniques described in this paper do not depend on a specific EM simulator, since third-party simulated or measured S-parameter data can be used to represent the antenna response. The corporate feed network is shown in Figure 2.

The power is input from the right side. Wilkinson dividers are used to split the signal and feed the 16 patches. Figure 3 shows the feed for a typical patch.

The transmit module and Wilkinson divider are shown in detail on the right side of Figure 3 and the inside of the transmit module on the left side. Each transmit module has a phase shifter, attenuator, and MMIC amplifier chip. The beam is steered by setting the phase and attenuation going into the MMIC amplifier and then sending the resulting signal to the patch. The phase and attenuation are controlled by variables in the software, which can be tuned and optimized as desired. In this manner, the beam can be scanned. Figure 4 shows the 3D view of the MMIC amplifier. It is a two-stage, 8-FET amplifier designed to work at X-band.

In this example, the feed network is simulated entirely in the circuit simulator. A more realis-

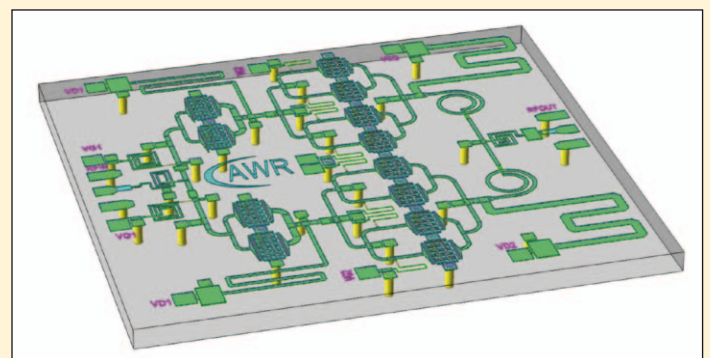

Figure 4: 3D layout view of the designed MMIC amplifier

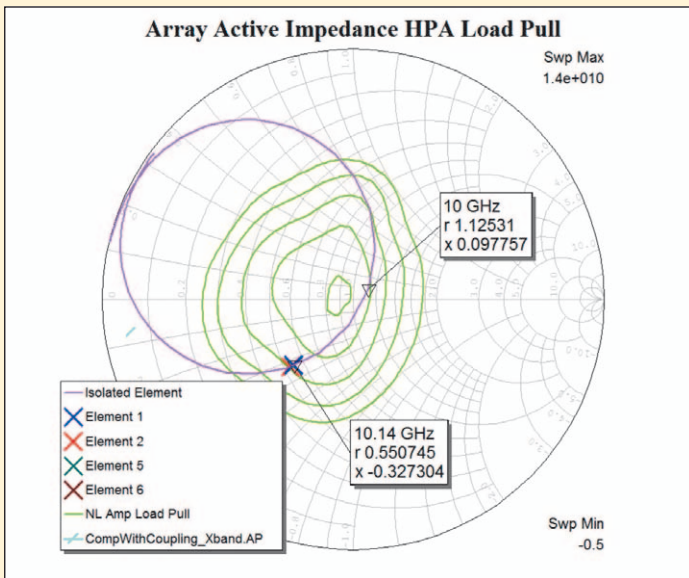

Figure 5: The Smith chart shows the Input impedance to an isolated element and to elements when the entire array is simulated. Load pull contours for power getting to the load are also shown

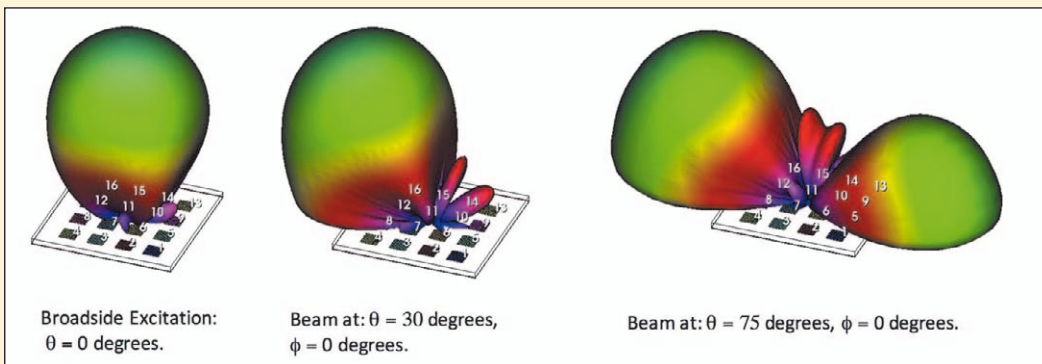

Figure 6: The beam of the array as it is scanned through typical values of theta and phi

tic example would simulate the layout of the feed network in an EM simulator to make sure the models are accurate and there is no unintended coupling between sections of the network.

Typical circuit simulation results are shown in Figure 5. The system is designed to work at 10 GHz. The purple curve shows the input impedance for an isolated patch from 6 to 14 GHz on a 50 Ohm normalized Smith chart. The marker shows the normalized impedance at 10 GHz. The four crosses show the input impedance of four typical elements at 10 GHz. Note that the interaction between the elements in the array shifts the input impedance of each element from that of an isolated

patch. The green contours are load-pull simulations for the MMIC amplifier, showing the power delivered to a load. The shifting of the impedances of the antenna feed results in a 0.5 dB degradation of power to the elements. (Figure 5 power contours are in 0.5 dB increments.)

Examples of the antenna pattern are shown in Figure 6. The beam is steered by controlling the relative phasing and attenuation to the various transmit modules. In practice, the harmonic balance takes substantial time to run with 16 power amplifiers. Therefore, the beam is steered with the amplifiers turned off. The designer then turns on the power amplifiers for specific points of interest. Note: the far right image

in Figure 6 shows a second lobe created when the main lobe is at a near grazing angle.

This second example is an 8X8 patch array. Anything that can be tuned in Microwave Office can also be optimized. For example, in Figure 7, the antenna pattern is optimized for a certain scan angle. In the interests of time, the amplifiers are not included in the optimization. At the end the amplifiers are turned on to see the amount of degradation. The plot is of the total power in the beam, scanning in the theta direction with phi at 0 degrees. The blue bars show the optimizer goals for the measurement. The purple pattern is the original broadside pattern. The optimizer changes the phase and attenuation at the feeds to the patches. The resulting blue curve meets

the optimization goal of scanning at 20 degrees with acceptable side lobe levels.

Conclusion

In conclusion, designing antennas with multiple feed points for communications or radar systems requires simulation of the interaction that occurs between the circuit, typically a highly nonlinear power amplifier, the feed network, and the antenna. The beam is steered by the circuitry, and as the beam changes the input impedance or input characteristics of the antenna change, which effects the circuit. The circuit and the antenna are connected, so both must be included in the simulation.

The traditional method of simulating antennas with multiple feeds is to simulate the coupled antenna/circuit effects manually using an iterative process that is time consuming and frustrating. Microwave Office circuit and antenna simulation are coupled together, enabling arrays to be easily excited from the amplifier and feed network. The load impedances of the array are incorporated into the circuit simulation. This automates the process, saving design time and delivering products to market faster. ◀

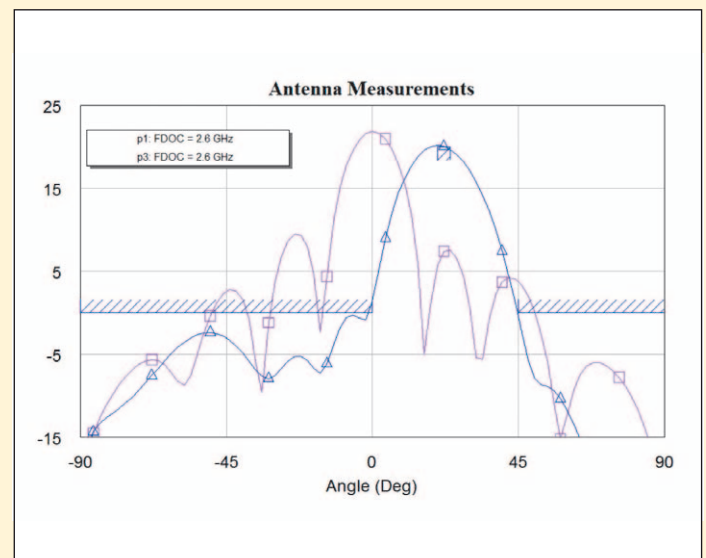

Figure 7: The antenna pattern is optimized to be below the blue bars